

- **Possibly the most stable transmitter in the world**
 - self-calibrating transmitter and ultra-low temperature coefficient for highest accuracy
- **One solution for all your needs**
 - designed for use in all water and waste water applications, from sewage plants to distribution networks
- **Quick transmitter exchange**
 - revolutionary data storage enables transmitter interchange without the need for reconfiguration
- **Advanced infrared service port**
 - supports simultaneous and parallel operation of HART, remote HMI, cyclic data output and parameter dump
- **Octagonal full-bore flow measurement sensor**
 - unique inner octagonal bore reduces sensitivity to flow profile disturbances
- **Verification to OIML R49 type 'P' requirements**
 - continuous self checking of the sensor and transmitter to ensure the highest accuracy and long term performance
- **NAMUR compliant diagnostics**
 - comprehensive diagnostics categorized into NAMUR NE107 classifications for clear diagnostic indication



The perfect fit for all water industry applications

The Company

We are an established world force in the design and manufacture of instrumentation for industrial process control, flow measurement, gas and liquid analysis and environmental applications. As a part of **ABB**, a world leader in process automation technology, we offer customers application expertise, service and support worldwide. We are committed to teamwork, high quality manufacturing, advanced technology and unrivalled service and support. The quality, accuracy and performance of the Company's products result from over 100 years experience, combined with a continuous program of innovative design and development to incorporate the latest technology. Over ten flow calibration plants are operated by the Company, which is indicative of our dedication to quality and accuracy.

Introduction

Setting the Standard

The WaterMaster range, available in sizes 40 to 2200 mm (1½ to 86 in), is designed specifically for use on the many diverse applications encountered in the Water and Waste-water industry.

The specification, features and user benefits offered by this range are based on ABB's worldwide experience in this industry and they are all targeted specifically to the industry's requirements.

Flow Performance

WaterMaster has an operating flow range with ± 0.4 % accuracy as standard (± 0.2 % optional) in both forward and reverse flow directions.

Submersible and Buriable

All WaterMaster sensors have a rugged, robust construction to ensure a long, maintenance-free life under the arduous conditions experienced in the Water and Waste Industry. The sensors are, as standard, inherently submersible (IP68, NEMA 6P), thus ensuring suitability for installation in chambers and metering pits which are liable to flooding.

A unique feature of the WaterMaster sensors is that all sizes are buriable; installation merely involves excavating to the underground pipe, fitting the sensor, cabling back to the transmitter and then backfilling the hole.

Comprehensive Features

A wide range of features and user benefits are built into WaterMaster as standard:

- bi-directional flow
- true electrode and coil impedance measurement
- comprehensive simulation mode
- universal switch mode power supply (options are available for AC and DC supplies)
- comprehensive self-diagnostics compliant with NAMUR NE107
- programmable multiple alarm capability
- unique, self-calibrating transmitter (patent approval in progress) for the ultimate in stability and repeatability
- OIML compliant, continuous self-checking, with alarms, ensures both sensor and transmitter accuracy
- HART protocol over 4 to 20 mA and infrared link
- 3 configurable pulse/frequency and alarm outputs
- advanced infrared service port supports remote HMI, HART, cyclic data out and parameter dump
- NAMUR compliant current output with alarm signalling
- Read-only switch and ultra-secure service password for total security.

Assured Quality

WaterMaster is designed and manufactured in accordance with international quality procedures (ISO 9001) and all flowmeters are calibrated on nationally-traceable calibration rigs to provide the end-user with complete assurance of both quality and performance of the meter.



WaterMaster – Electromagnetic Flowmeter

The perfect fit for all water industry applications

Unrivalled in its scope and applications expertise, ABB offers the world's most comprehensive range of flow measurement products. The FlowMaster family of products is unsurpassed in the number of proven measurement techniques, variety of models and scope of application and includes the WaterMaster range of Electromagnetic Flowmeters.

Getting the best levels of efficiency and performance from your production process requires reliable, accurate instrumentation. WaterMaster provides the flexibility to solve your most demanding water applications enabling previously unattainable operational and financial benefits. WaterMaster is the ultimate solution for flow measurement and management in sectors as diverse as water, wastewater, sewage and effluent.

WaterMaster delivers speed, simplicity and ease of use at every stage of the product's lifecycle. In fact, WaterMaster doesn't just plug the gaps left by competitive products, it is simply the best flow metering solution available today.

Superior control through advanced sensor design

Innovative, patented octagonal sensor design improves flow profile and reduces up- and down-stream piping requirements for the most commonly used sizes of 40 to 300 mm (1½ to 12 in).

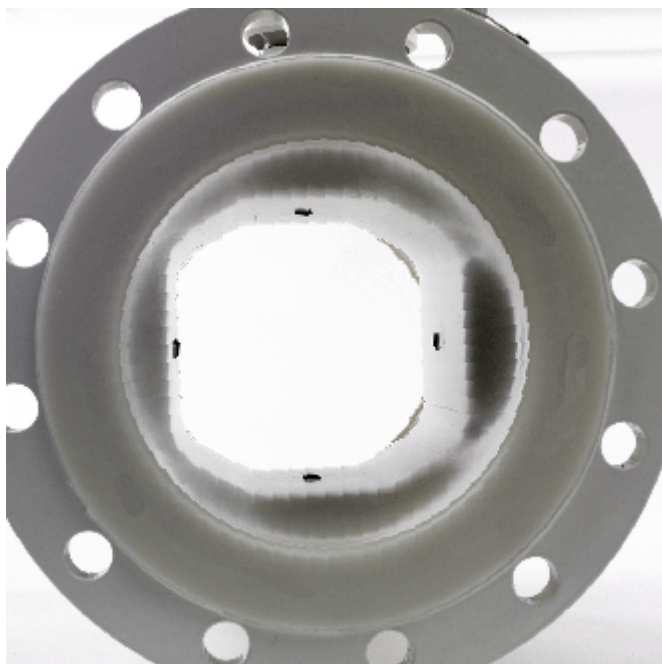

Octagonal Bore

Using a unique, controlled derivative excitation combined with advanced filtering, WaterMaster improves accuracy by raising zero stability to new levels, resulting in higher accuracy measurements.

Proven in the toughest applications, WaterMaster's rugged, robust and buriable sensors eliminate the need for expensive meter chambers thus providing a long, productive and maintenance-free asset life.

Powerful and flexible transmitter

The backlit, graphical display is rotated easily up to 270 degrees without any tools, enabling users to position it as best fits their needs. 'Through-the-glass' control allows local operator interface to enable short, quick data entry for all user-specific parameters.



Transmitter Display

ABB's universal Human Machine Interface (HMI) simplifies operation, maintenance and training; thereby reducing cost of ownership and providing one common user experience.

All product versions utilize a common electronics cartridge to simplify installation and reduce the number of spare parts. The same cartridge is used in both integral and remote installations and features active current and passive pulse outputs. Standard HART protocol enables online modification and monitoring of parameters.

Intuitive navigation and configuration

The user-friendly interface allows fast and simple data entry for all parameters. 'Easy Setup' guides the operator step-by-step through the menu to set parameters as quickly as possible, thereby simplifying the commissioning phase.

Improved Performance through Digital Signal Processing (DSP)

Advanced Digital Signal Processing (DSP) gives improved performance and enables real time measurements for maximum reliability.

DSP enables the transmitter to separate the real signal from the noise, therefore providing high quality outputs especially in harsh environments involving vibration, hydraulic noise and temperature fluctuation.

Speed, ease and security in the field

'Fit-and-Flow' data storage inside the WaterMaster eliminates the need to match sensor and transmitter in the field. On initial installation, the self-configuration sequence automatically replicates into the transmitter all calibration factors, meter size and serial numbers, as well as customer site-specific settings, eliminating the opportunity for error.

This redundant storage of data in both the sensor and transmitter memory is continually updated during all operations to ensure the integrity of the measurement.



Transmitter with Infrared Communications Device Attached

Detailed diagnostics for rapid decision making

WaterMaster is proven to be robust and reliable, with unmatched diagnostic capabilities providing the correct information to keep your process up and running. In accordance with NAMUR NE107, alarms and warnings are classified with the status of 'maintenance required', 'check function', 'failure' and 'out of specification'.

The following screen shows an alarm history with the number of occurrences for the alarm together with time durations.

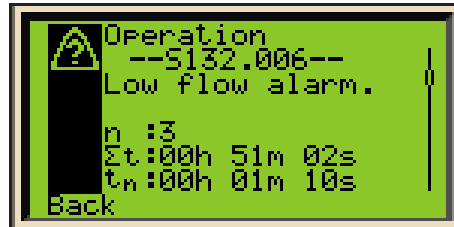

Diagnostics Display

Advanced infrared service port

WaterMaster as standard incorporates an infrared service port that enables the meter's configuration to be saved externally and transferred to additional or replacement units if required.

If a customer alters the configuration and causes the instrument to behave erratically, the infrared service port enables ABB technicians to assist in troubleshooting the problem by allowing easy, remote access to the configuration data.

The infrared service port is used to interrogate the HMI menu items automatically and dump the HMI parameter settings and cyclic output measured values (such as flowrate and diagnostic measurement) through the service port to a terminal program; data can then be downloaded to a PC and saved to a terminal application, from where it can be output as text or spreadsheet data.

Attention to the smallest technical detail delivers big operational benefits

ABB's WaterMaster sets the standard for flow measurement and management applications in the water, sewage and effluent industries.

Leveraging advanced technology, WaterMaster delivers the power to solve your most demanding applications, enabling previously unattainable operational and financial benefits.

The perfect balance of power, performance, flexibility and control

With WaterMaster, flexible doesn't mean complicated. Take advantage of its innovative and versatile attributes to achieve interoperability within a wide range of asset management systems. WaterMaster, the best solution for your flow measurement needs.

Now the best in class is even better!



The WaterMaster Family

WaterMaster Specification to OIML R49

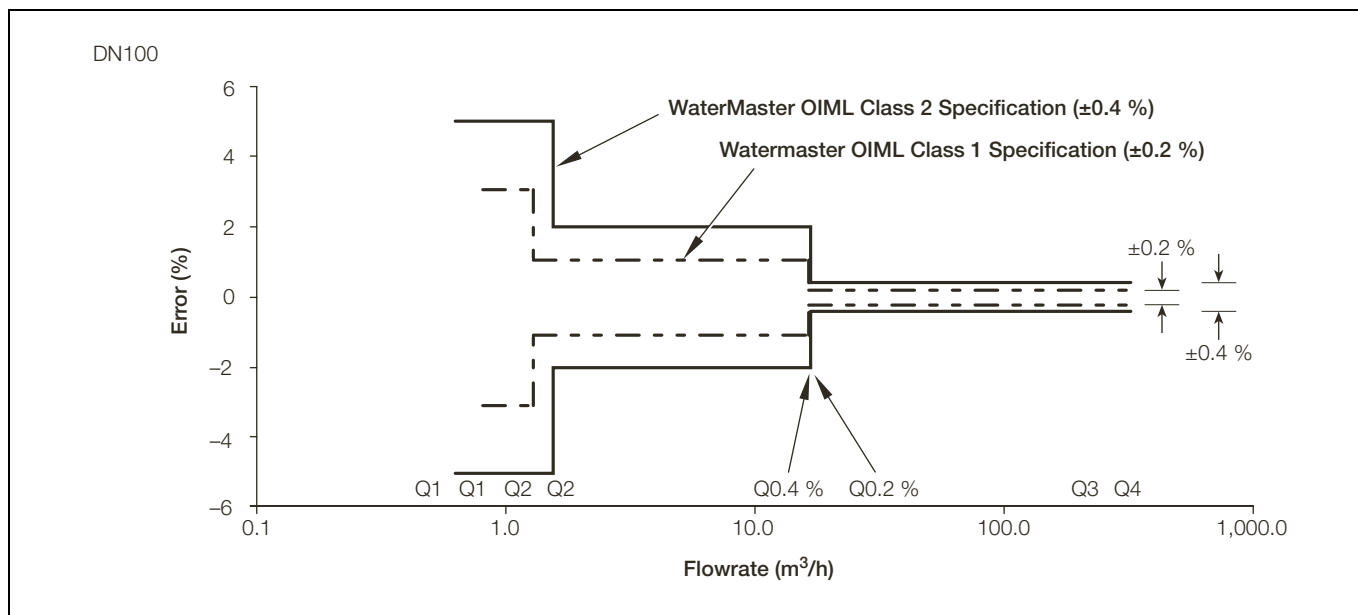

Organization Internationale de Métrologie Légale (OIML)

What is OIML?

The OIML is an inter-governmental body, established in 1955. Its main objective is to achieve international harmonisation for legal metrology, providing an important basis for measurement credibility, eliminating technical barriers to the trade in measuring instruments and promoting international trade by confidence in measurement capability.

The main output of OIML's work is the production of International Recommendations (such as R49), which are technically based models for legal control of measuring instruments.

Definition of legal metrology

Legal Metrology is the entirety of the legislative, administrative and technical procedures established by, or by reference to public authorities, and implemented on their behalf in order to specify and to ensure, in a regulatory or contractual manner, the appropriate quality and credibility of measurements related to official controls, trade, health, safety and the environment.

OIML certificate system for measuring instruments

The OIML certificate system for measuring instruments was introduced in 1991 to facilitate administrative procedures and lower the costs associated with the international trade of measuring instruments subject to legal requirements.

The System provides the possibility for a manufacturer to obtain an OIML Certificate and a Test Report indicating that a given instrument type (pattern) complies with the requirements of the relevant OIML International Recommendations.

OIML R49

Under EU Measuring Instruments Directive (MID) 2004/24/EC, that includes Water Meters for certain applications, conformity can be achieved by various routes. WaterMaster conformity is being sought through the OIML International Recommendation known as R49-1(2006), a Recommendation for cold potable water and hot water meters. The OIML has very similar requirements to the latest ISO4064 and EN14154 standards, but allows the option of a higher accuracy, Class 1 (1%), classification. WaterMaster is designed to meet this very highest accuracy designation with a wide flowrate turndown ratio. A major advance in WaterMaster is the self checking capabilities designed to meet the R49 requirements, with continuous OIML Type 'P' self checking during normal operation (not just at startup) and alarm indication for:

- transmitter and sensor status, with an accuracy alarm
- program ROM and RAM status
- double, independent storage of totalizer values, in both the sensor and transmitter non-volatile memories
- display test

OIML R49 is in 2 parts and can be downloaded from the OIML web site. To download the documents, enter the following addresses in the web browser's address bar:

<http://www.oiml.org/publications/R/R049-1-e06.pdf>

<http://www.oiml.org/publications/R/R049-2-e06.pdf>

WaterMaster Flow Performance

DN			Standard Calibration 0.4 % OIML R49 Class 2			High Accuracy Calibration 0.2 % OIML R49 Class 1		
	Q4 (m ³ /h)	Q3 (m ³ /h)	Q (m ³ /h)	Q2 (m ³ /h)	Q1 (m ³ /h)	Q (m ³ /h)	Q2 (m ³ /h)	Q1 (m ³ /h)
40	50	40	2.7	0.25	0.1	5	0.3	0.2
50	79	63	4.2	0.4	0.16	8	0.5	0.32
65	125	100	6.7	0.63	0.25	13	0.8	0.5
80	200	160	11	1	0.4	16	1.3	0.8
100	313	250	17	1.6	0.63	25	2	1.3
125	500	400	27	2.5	1	40	3.2	2
150	788	630	42	4	1.6	63	5	3.2
200	1,250	1,000	67	6.3	2.5	100	8	5
250	2,000	1,600	107	10	4.0	160	13	8
300	3,125	2,500	167	16	6.3	250	20	13
350	5,000	4,000	267	25	10	400	32	20
400	5,000	4,000	267	25	10	400	32	20
450	7,875	6,300	420	39	16	630	50	32
500	7,875	6,300	420	39	16	630	50	32
600	12,500	10,000	667	63	25	1000	80	50
700	20,000	16,000	1067	100	40	1600	160	100
760	20,000	16,000	1067	100	40	1600	160	100
800	20,000	16,000	1067	100	40	1600	160	100
900	31,250	25,000	1667	156	63	2500	250	156
1000	31,250	25,000	1667	156	63	2500	250	156
1050	31,250	25,000	1667	156	63	2500	250	156
1200	50,000	40,000	2667	250	100	4000	400	250
1400	78,750	63,000	4200	394	158	6300	630	394
1500	78,750	63,000	4200	394	158	6300	630	394
1600	78,750	63,000	4200	394	158	6300	630	394
1800	125,000	100,000	6667	625	250	10000	1000	625
2000	125,000	100,000	6667	625	250	10000	1000	625
2200	125,000	100,000	6667	625	250	10000	1000	625

Sensor Dimensions

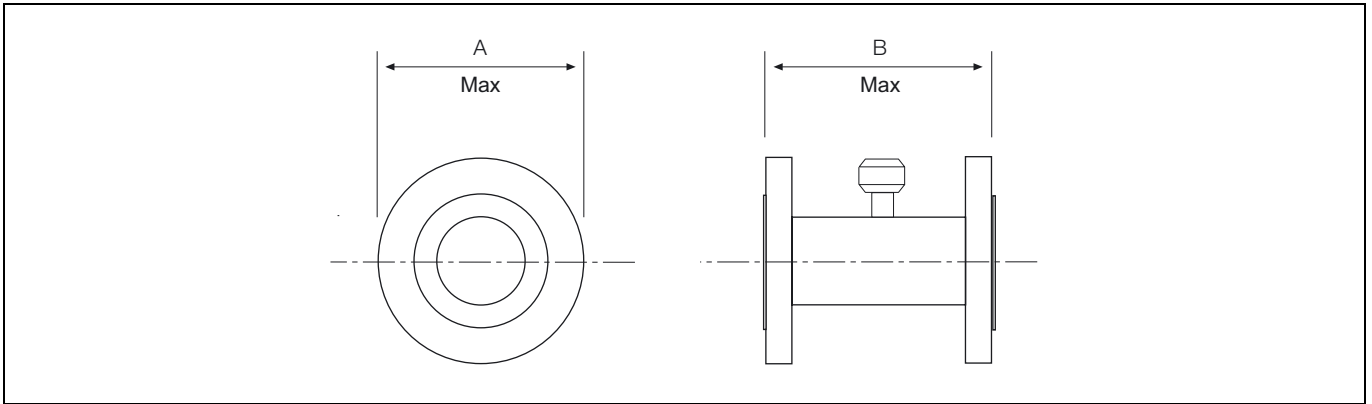

DN 40 to 300 Full-bore

Meter Size		Dimensions mm (in)		Approximate Weight	
DN	NPS/NB	A*	B	kg	lb
40	1½	150 (5.9)	200 (7.9)	11	24
50	2	165 (6.5)	200 (7.9)	12	27
80	3	200 (7.9)	200 (7.9)	15	33
100	4	230 (9.1)	250 (9.8)	18	40
150	6	280 (11.0)	300 (11.8)	31	68
200	8	345 (13.6)	350 (13.8)	48	106
250	10	405 (15.9)	450 (17.7)	75	165
300	12	460 (18.1)	500 (19.7)	112	247

*Dimensions are approximate and vary depending on flange type

DN 40 to 300 Full-bore

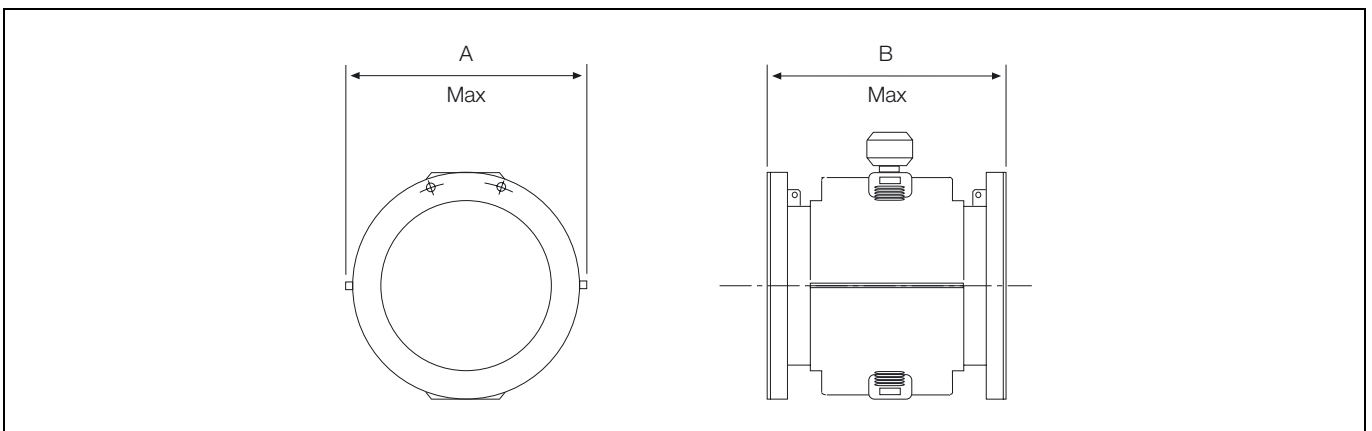

DN 350 to 600 Full-bore

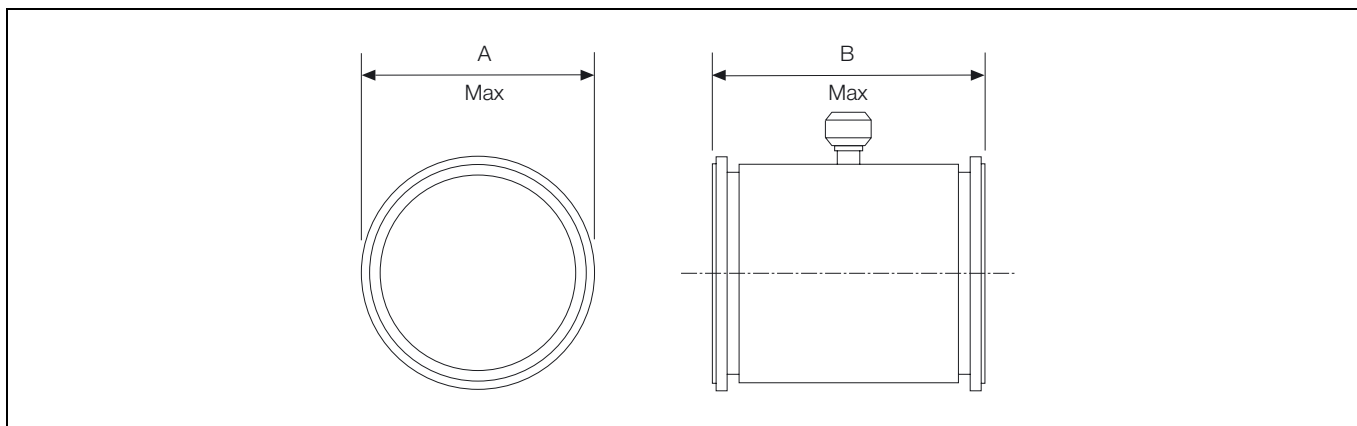

DN 700 to 2200 Full-bore

Meter Size		Dimensions in mm (in)		Approximate Weight	
DN	NPS/NB	A	B	kg	lb
350	14	535 (21.1)	550 (21.7)**	100	220
400	16	600 (23.6)	600 (23.6)**	115	253
450	18	640 (25.2)	698 (27.5)**	160	352
500	20	715 (28.1)	768 (30.2)**	217	455
600	24	840 (33.1)	918 (36.1)**	315	693
700	27/28*	927 (36.5)	700 (27.6)***	430	945
750	30	985 (38.8)	762 (30)***	430	945
800	32	1060 (41.7)	800 (31.5)***	430	945
900	36	1170 (46.1)	900 (35.4)***	540	1190
1000	39/40*	1290 (50.8)	1000 (39.4)***	720	1585
1100	42	1405 (55.3)	1067 (42)***	880	1930
1200	48	1511 (59.5)	1200 (47.2)***	1000	2160
1400	54	1745 (68.7)	1400 (55.1)***	1450	3190
1500	60	1855 (73.0)	1524 (59)***	1370	3000
1600	66	2032 (80.0)	1600 (63)***	2000	4400
1800	72	2197 (86.5)	2250 (88.6)***	2400	5280
2000	78	2362 (93.0)	2500 (98.4)***	3200	7040
2200	84	2534 (100.0)	2750 (110)***	4200	9300

* Size is dependent on flange specification

Typical tolerances: **+0/-6 mm (0.24 in); ***+0/-10 mm (0.40 in)

Items **/** DN700 up +0/-25 mm (1.0 in) if using WN flanges

DN 350 to 2200 Full-bore

Transmitter Dimensions

Integral Transmitter

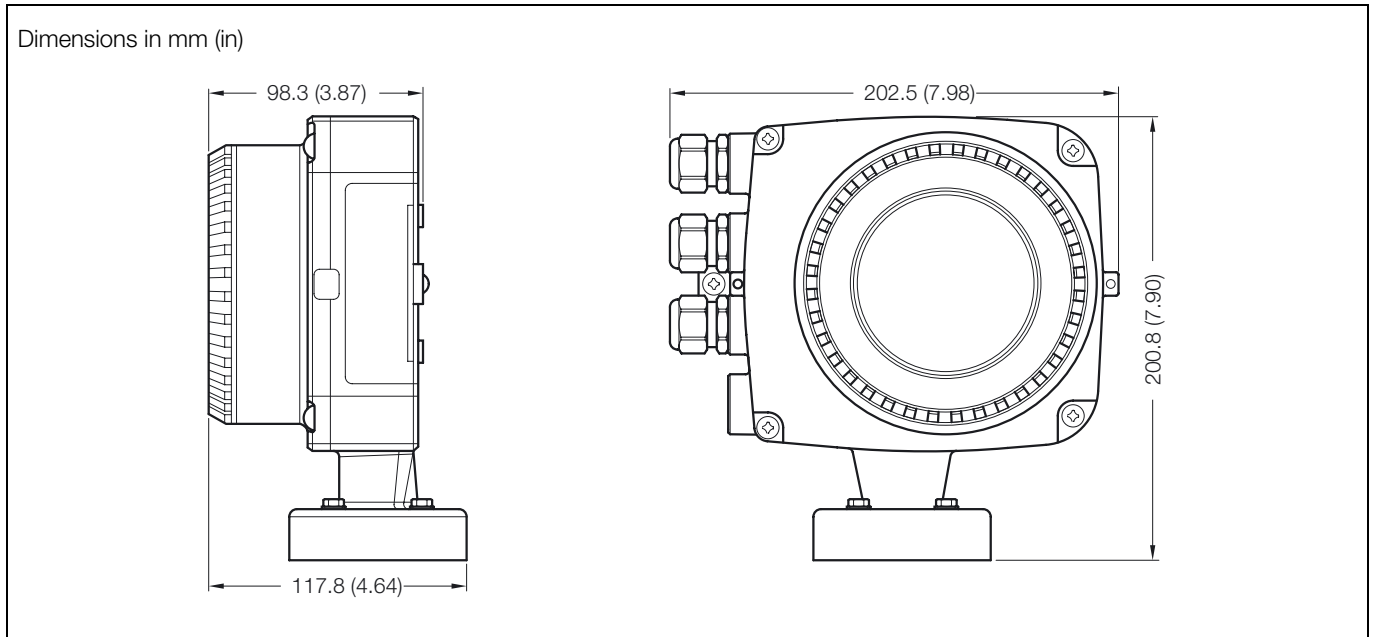

Remote Transmitter

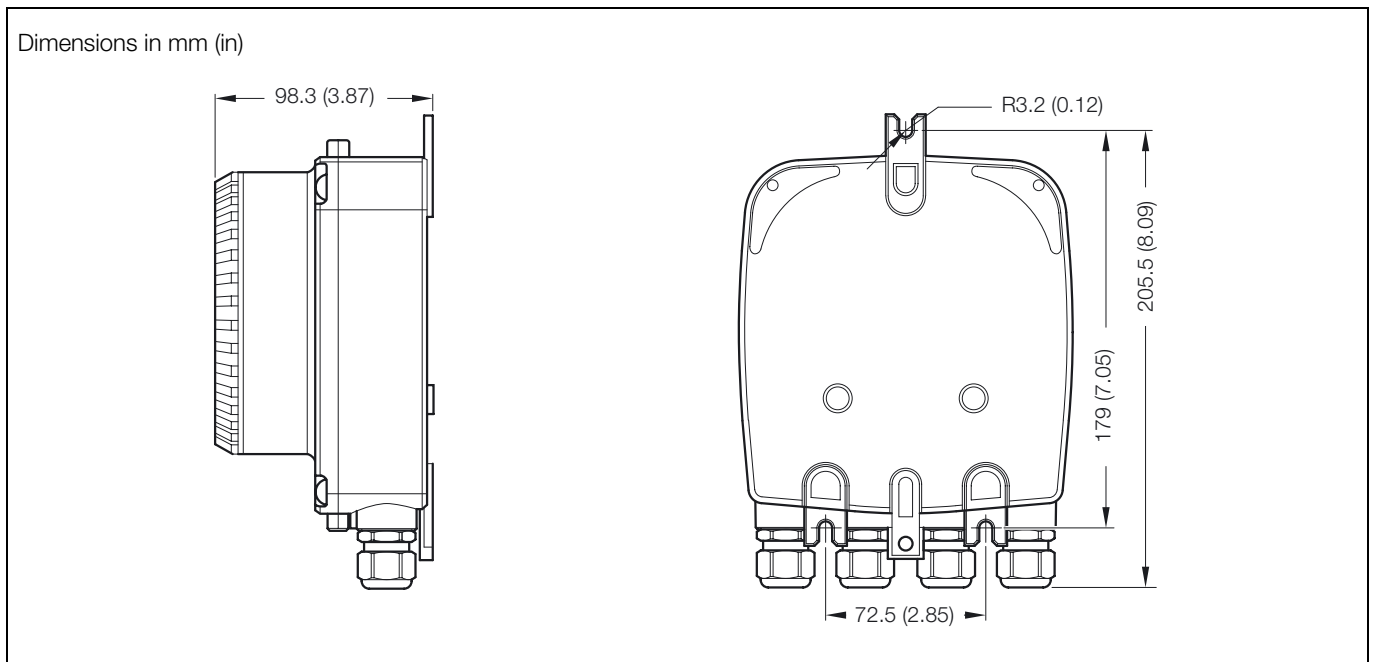

Electrical Connections

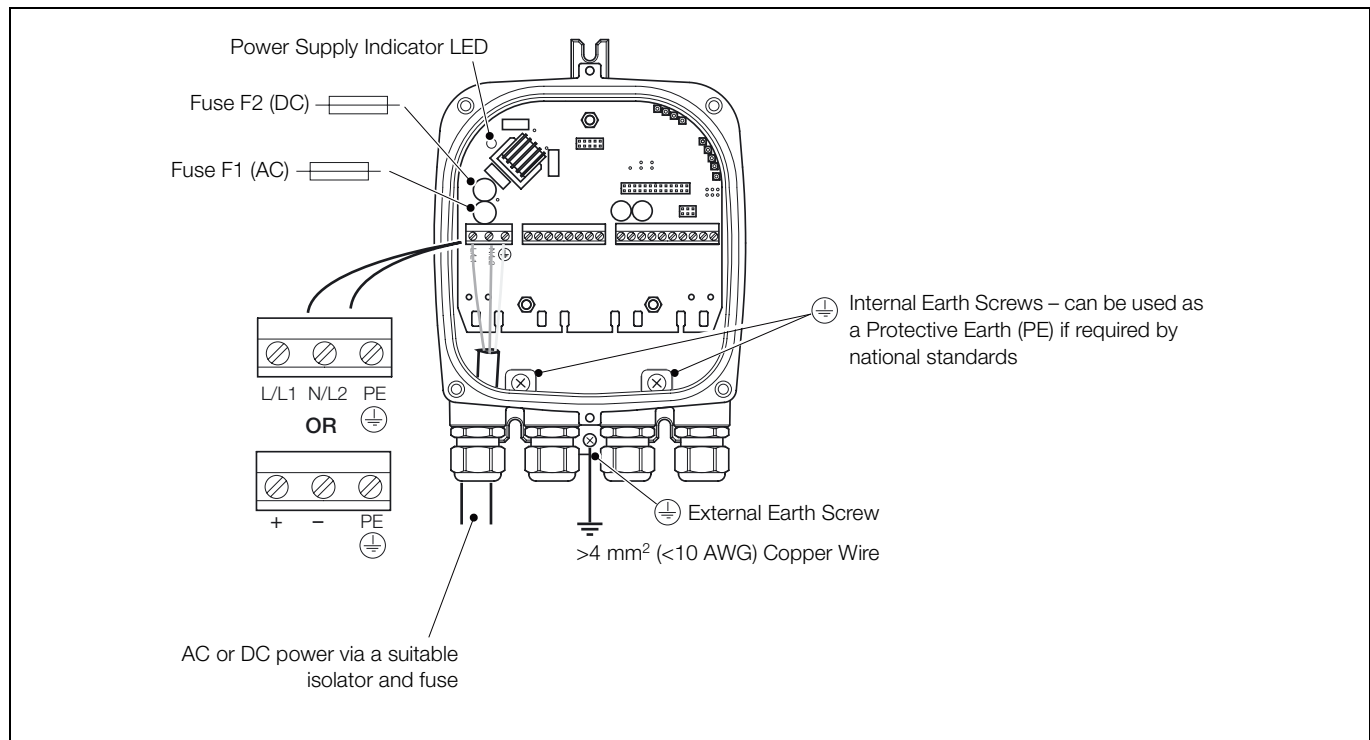

AC and DC Power Supply Connections

Ordering Information

WaterMaster Electromagnetic Flowmeter	WaterMaster	FE	X	XX	1	XXX	X	X	
	Code Digits		1	2,3	4	5,6,7	8	9	10 ... 16
Sensor Type									
WaterMaster DN 40 ... DN 200 (1½ ... 8 in)			V						
WaterMaster DN 250 ... DN 2200 (10 ... 88 in)			F						
Transmitter only			T						
Transmitter Type / Transmitter Housing Type									
Without transmitter					00				
WaterMaster transmitter module					10				
WaterMaster transmitter / integral					11				
WaterMaster transmitter / remote					12				
Sensor only, for use with remote WaterMaster transmitter					18				
Sensor only, for use with integral WaterMaster transmitter					19				
Bore Diameter									
DN 40 (1½ in)						040			
DN 50 (2 in)						050			
DN 80 (3 in)						080			
DN 100 (4 in)						100			
DN 125 (5 in)						125			
DN 150 (6 in)						150			
DN 200 (8 in)						200			
DN 250 (10 in)						250			
DN 300 (12 in)						300			
DN 350 (14 in)						350			
DN 400 (16 in)						400			
DN 450 (18 in)						450			
DN 500 (20 in)						500			
DN 600 (24 in)						600			
DN 700 (28 in)						700			
DN 760 (30 in)						760			
DN 800 (32 in)						800			
DN 900 (36 in)						900			
DN 1000 (40 in)						001			
DN 1050 (42 in)						051			
DN 1100 (44 in)						101			
DN 1200 (48 in)						201			
DN 1400 (54 in)						401			
DN 1500 (60 in)						501			
DN 1600 (66 in)						601			
DN 1800 (72 in)						801			
DN 2000 (80 in)						002			
DN 2200 (88 in)						202			
Without sensor (replacement transmitter only)						000			
Liner Material									
Elastomer (DN250 ... DN2200)								K	
Elastomer with ACS and NSF61 approval (DN250 ... DN2200)								L	
Polypropylene (DN40 ... DN200)								V	
Without (transmitter only)								Y	
Electrode Design									
Without (transmitter only)									0
Standard									1

Continued on page 14

WaterMaster Electromagnetic Flowmeter	X	X	XX	X	1	X	1	
Continued from page 13 (Code Digits 1 to 9)	10	11	12,13	14	15	16	17	18 ... 25
Measuring Electrodes Material								
Stainless steel 316	S							
Without (transmitter only)	Y							
Grounding Accessories								
Without		0						
One ground ring		1						
Process Connection Type								
Flanges ANSI / ASME B16.5 / 16.47 series B class 150 (DN40 ... DN600)			A1					
Flanges AWWA C207 class B (700 ... 1600 mm)			C1					
Flanges AWWA C207 class D (700 ... 1600 mm)			C2					
Flanges AS 4087 Class 16 (DN40 ... DN2200)			E1					
ISO 7005 PN16 EN1092-1 (DN40 ... DN2200)			S2					
Process Connection Material								
Carbon steel flanges				B				
Without (transmitter only)				Y				
Calibration Type								
Standard OIML R49 Class 2 calibration – without fingerprint						A		
High accuracy OIML R49 Class 1 calibration – without fingerprint						B		
Witnessed OIML R49 Class 1 calibration						M		
Transmitter only						Y		

Continued on page 15

WaterMaster Electromagnetic Flowmeter			X	X	X	X	X	X	X	X
Continued from page 13	Code Digits 1 to 9	Code Digits 10 to 17	18	19	20	21	22	23	24	25
Continued from page 14										
Language										
English			A							
German			D							
French			G							
Spanish			K							
Italian			N							
Signal Cable Length and Type										
Without signal cable				0						
5 m (15 ft.) standard cable				1						
10 m (30 ft.) standard cable				2						
20 m (60 ft.) standard cable				3						
30 m (100 ft.) standard cable				4						
50 m (165 ft.) standard cable				5						
80 m (260 ft.) standard cable				6						
100 m (325 ft.) standard cable				7						
150 m (490 ft.) standard cable				8						
Special Length > 150 m (> 490 ft.) and/or armored cable				9						
Explosion Protection Certification										
General purpose (non-Ex design)								A		
Without (transmitter only)								Y		
Protection Class Transmitter / Protection Class Sensor										
IP67 (NEMA 4X) / IP68 (NEMA 4X) – cable not fitted. Available only with transmitter type / transmitter housing type code 12, 18 (remote transmitter)							2			
IP67 (NEMA 4X) / IP68 (NEMA 4X) – cable fitted and potted. Available only with transmitter type / transmitter housing type code 12, 18 (remote transmitter)							3			
Cable Conduits										
M20 x 1.5								A		
NPT 1/2 in								B		
M20 SWA armored								D		
Power Supply										
Without (sensor only)								0		
100 ... 230 V AC, 50 Hz								1		
24 V AC / DC, 50 Hz								2		
100 ... 230 V AC, 60 Hz								3		
24 V AC / DC, 60 Hz								4		
Input and Output Signal Type										
HART + 20 mA + pulse + contact output									A	
Without (sensor only)									Y	
Configuration Type / Diagnostics Type										
Without (sensor only)										0
Standard diagnostics										1

ABB has Sales & Customer Support expertise
in over 100 countries worldwide

www.abb.com

The Company's policy is one of continuous product
improvement and the right is reserved to modify the
information contained herein without notice.

Printed in UK (10.07)

© ABB 2007



ABB Limited
Oldends Lane, Stonehouse
Gloucestershire
GL10 3TA
UK
Tel: +44 (0)1453 826661
Fax: +44 (0)1453 829671

ABB Inc.
125 E. County Line Road
Warminster
PA 18974
USA
Tel: +1 215 674 6000
Fax: +1 215 674 7183