

## Pressure gauge with diaphragm seal ISO 2852, 1½ clamp

### Type A45 - Plus Line

Date: October 2002

Sheet No.: 1-620 GB

### The most cost effective gauge in the market

#### Tempress offers:

- Gauge manufactured to the ISO 9001 certification
- Reliable, accurate and high quality products
- Competent and professional advice
- Longstanding experience as a manufacturer to the food and pharmaceutical industry

#### Application

For measuring pressure:

- In bio-chemical tanks
- Across water filters
- Process lines

The Tempress Plus Line pressure gauge is made as an alternative to the Tempress type A33 High quality gauge.

The Plus Line gauges are liquid filled and equipped with external temperature compensation (as shown on the photo). At an ambient temperature of 20 deg. C the accuracy is specified as cl. 1.6 % for the assembled DN100 gauge with diaphragm seal and cl. 2.5 % for the DN 63 gauge.

The DN 63 gauge can be made in a special high temperature version with cooling ribs, for media temperature up to 200 deg. C.

#### DN 63 or DN 100 pressure gauge with 1½ clamp

- Standard media temperature DN 63 max. 100° C
- Standard media temperature DN 100 max. 130° C
- Liquid filled
- Bottom or Rear connection
- Special high temperature version of the DN 63 gauge with cooling ribs for media temperature up to 200° C

#### Options

- Certificate EN 10204-2.2
- Customer logo

Specifications	
Type	DN 63: A4501 DN 100: A4503
Case diameter	DN 63 or DN 100
Case material	Stainless steel
Glass face	Standard: Acrylic High temp.: Polycarbonate
Connection	Bottom or rear
Liquid filling	Glycerine or silicone oil
Span	DN 63: Minimum 4 bar span DN 100: Minimum 2,5 bar span
Ranges	Standard ranges from -1 to 60 bar (Multiscale)
Ambient temperature	0-60° C (Glycerine filled) -40/+50° C (Silicone oil filled)
Accuracy of gauge DN 63	EN 837-1 Class 1.6 (±1.6%FS)@ 20° C
Accuracy of gauge DN 100	EN 837-1 Class 1.0 (±1.0%FS)@ 20° C
Accuracy of diaphragm seal	Add to instrument accuracy +0,5% for direct mounting
Other specifications	Consult TEMPRESS

TEMPRESS reserves the right to changes without notice

Agent/Dealer:



### TEMPRESS A/S

Nordlandsvej 64-66  
DK-8240 Risskov, Denmark  
Tel.: +45 8932 5210  
Fax.: +45 8932 5213  
sales@tempress.dk  
www.tempress.dk

## Diaphragm seal-DN 38

TR76

Date: January 2003

Sheet No.: 1-876GB

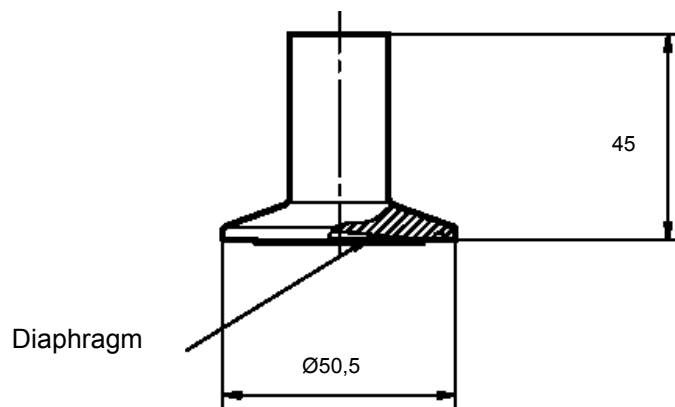

Type			Measuring range	
Data sheet	instrument	Type	Min. span	Max. pressure
1-600	Pressure gauge	A32, A33, A37	1 bar (15 psi)	150 bar (2200 psi)
2-600	Pressure transmitter	P1232	0,25 bar (4 psi)	150 bar (2200 psi)

Transmission liquid			
Application	Liquid type	Temp range	Span
Standard:	Glycerine 90/10	-5/+130 °C (+23/+266 °F)	All
Low temperature:	Glycerine 75/25	-40/+100 °C (-40/+212 °F)	All
High temperature:	Glycerine	+5/+200 °C (+41/+392 °F)	≥4 bar (60 psi)

Diaphragm seal			
Diaphragm seal:	TR	...	...
<b>Wetted parts:</b>			
AISI 316L		76	
<b>Diaphragm:</b>			
AISI 316L	Ra 0.8 µm (Ra 32 µ")		04
AISI 316L, electropolished	Ra 0.5 µm (Ra 20 µ")		08
<b>Example:</b>	Diaphragm seal with wetted parts and diaphragm in AISI 316		TR7604

TEMPRESS reserves the right to changes without notice

Agent/Dealer:



### TEMPRESS A/S

Nordlandsvej 64-66  
 DK-8240 Risskov, Denmark  
 Tel.: +45 8932 5200  
 Fax.: +45 8932 5213  
[tempress@tempress.dk](mailto:tempress@tempress.dk)  
[www.tempress.dk](http://www.tempress.dk)