



## OPTIFLUX 1000 **Technical Datasheet**

Electromagnetic flow sensor in sandwich version

- Basic and fully functional flow sensor
- Excellent price performance ratio
- Quick and easy to install and operate



The documentation is only complete when used in combination with the relevant documentation for the signal converter.

1	Product features	3
1.1	Economic and ecological solution for various industries	3
1.2	Options	5
1.3	Measuring principle	6
2	Technical data	7
2.1	Technical data	7
2.2	Dimensions and weights	11
2.3	Measuring accuracy	13
3	Installation	14
3.1	Notes on installation	14
3.2	Intended use	14
3.3	Installation conditions	14
3.3.1	Inlet and outlet	14
3.3.2	Mounting position	14
3.3.3	Flange deviation	15
3.3.4	T-section	15
3.3.5	Vibration	15
3.3.6	Magnetic field	16
3.3.7	Bends	16
3.3.8	Open discharge	17
3.3.9	Control valve	17
3.3.10	Air venting	17
3.3.11	Pump	18
3.3.12	Temperatures	18
4	Electrical connections	19
4.1	Safety instructions	19
4.2	Grounding	19
4.3	Virtual reference for IFC 300 (C, W and F version)	20
5	Notes	21

## 1.1 Economic and ecological solution for various industries

The **OPTIFLUX 1000** electromagnetic flow sensor is the economic and ecological solution for various industries, ranging from agriculture to utilities and from fire fighting to machinery.

The instrument is economical due to low investment and maintenance costs; it is ecological due to accurate measurements and no waste.

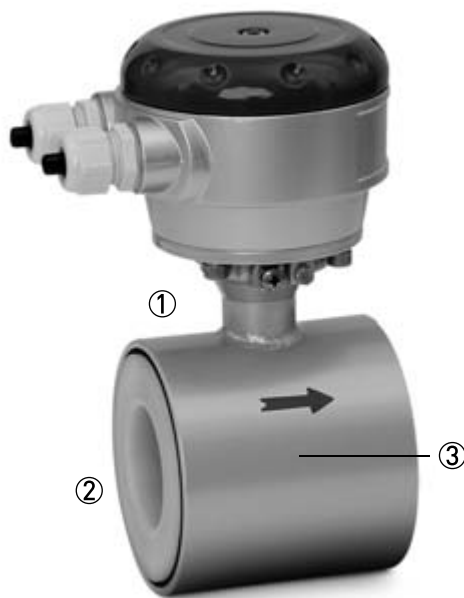

- ① Sandwich design
- ② PFA liner
- ③ Hastelloy electrodes

## Highlights

- Sandwich design
- Easy to install and operate
- Maintenance free

## Industries

- Agriculture
- Fire-fighting
- Machinery and apparatus construction
- Swimming pools and recreational facilities

## Applications

- Precise dosing of liquid fodder, liquid fertilizers, measurement of liquid manure, sprinkler irrigation systems
- Vehicles, fire extinguishing systems: foam mixing, control of sprinkler systems
- Heat counters, energy allocation to buildings and workshops
- Water recirculation and treatment

## 1.2 Options

### The economic solution with standard functionality



The OPTIFLUX 1000 electromagnetic flow sensor is an economical solution for a wide range of applications. The flowmeter can be used in applications (including various aqueous solutions), where other measurement techniques were previously used.



The OPTIFLUX 1000 is available in an diameter range of DN10 up to DN150 and is configurable with the IFC 100 and the IFC 300 signal converter. Only in combination with the IFC 300 converter, the sensor can be used for custody transfer applications.

### 1.3 Measuring principle

An electrically conductive fluid flows inside an electrically insulated pipe through a magnetic field. This magnetic field is generated by a current, flowing through a pair of field coils. Inside of the fluid, a voltage  $U$  is generated:

$$U = v * k * B * D$$

in which:

$v$  = mean flow velocity

$k$  = factor correcting for geometry

$B$  = magnetic field strength

$D$  = inner diameter of flow meter

The signal voltage  $U$  is picked off by electrodes and is proportional to the mean flow velocity  $v$  and thus the flow rate  $q$ . A signal converter is used to amplify the signal voltage, filter it and convert it into signals for totalising, recording and output processing.

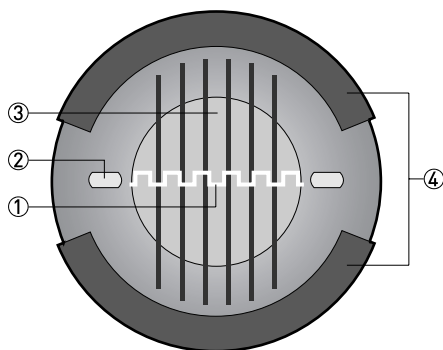

- ① Induced voltage (proportional to flow velocity)
- ② Electrodes
- ③ Magnetic field
- ④ Field coils

## 2.1 Technical data

- *The following data is provided for general applications. If you require data that is more relevant to your specific application, please contact us or your local representative.*
- *Additional information (certificates, special tools, software,...) and complete product documentation can be downloaded free of charge from the website (Download Center).*

### Measuring system

Measuring principle	Faraday's law of induction
Application range	Electrically conductive fluids
<b>Measured value</b>	
Primary measured value	Flow velocity
Secondary measured value	Volume flow, mass flow, electrical conductivity, coil temperature

### Design

Features	Sandwich version
Modular construction	The measurement system consists of a flow sensor and a signal converter. It is available as compact and as separate version. More information about the signal converter can be found in the documentation of the signal converter.
Compact version	With IFC 100 converter: OPTIFLUX 1100 C
	With IFC 300 converter: OPTIFLUX 1300 C
Remote version	In wall (W) mount version with IFC 100 converter: OPTIFLUX 1100 W
	In field (F), wall (W) or rack (R) mount version with IFC 300 converter: OPTIFLUX 1300 F, W or R
Nominal diameter	DN10...150 / 3/8...6"
Measurement range	-12...+12 m/s / -40...+40 ft/s

## Measuring accuracy

Reference conditions	Flow condition similar to EN 29104
	Medium: Water
	Electrical conductivity: $\geq 300 \mu\text{S/cm}$
	Temperature: $+10\dots+30^\circ\text{C}$ / $+50\dots+86^\circ\text{F}$
	Flow velocity: $> 1 \text{ m/s}$ / $> 3 \text{ ft/s}$
	Operating pressure: 1 bar / 14.5 psig
	Wet calibrated on EN 17025 accredited calibration rig by direct volume comparison.
Maximum measuring error	Related to volume flow (MV = Measured Value)
	These values are related to the pulse / frequency output.
	The additional typical measuring deviation for the current output is $\pm 10 \mu\text{A}$ .
	For information refer to <i>Measuring accuracy</i> on page 13.
Repeatability	$\pm 0.1\%$ of MV, minimum 1 mm/s
Long term stability	$\pm 0.1\%$ of MV
Special calibration	On request

## Operating conditions

<b>Temperature</b>	
Process temperature	$-25\dots+120^\circ\text{C}$ / $-13\dots+248^\circ\text{F}$
Maximum temperature change (shock)	$120^\circ\text{C}$ / $248^\circ\text{F}$
Ambient temperature	$-25\dots+65^\circ\text{C}$ / $-13\dots+149^\circ\text{F}$
Storage temperature	$-50\dots+70^\circ\text{C}$ / $-58\dots+158^\circ\text{F}$
<b>Pressure</b>	
Ambient pressure	Atmospheric
Nominal flange pressure	<b>Standard:</b>
EN 1092-1	DN100... DN150: PN 16
	DN10...80: PN 40
ASME B16.5	<b>Standard:</b>
	3/8...6": 150 lb RF
	<b>Option:</b>
	3/8...4": 300 lb RF
JIS	DN10...100 / 3/8...4": 20 K
	DN150 / 6": 10 K
Vacuum load	0 mbar / 0 psi absolute
Pressure ranges for secondary containment	Pressure resistant up to 40 bar / 580 psi
	Burst pressure up to approx. 160 bar / 2320 psi



<b>Chemical properties</b>	
Physical condition	Liquids
Electrical conductivity	<b>Non water:</b>
	≥ 5 μS/cm
	<b>Water:</b>
≥ 20 μS/cm	
Permissible gas content (volume)	IFC 100: ≤ 3%
	IFC 300: ≤ 5%
Permissible solid content (volume)	IFC 100: ≤ 10%
	IFC 300: ≤ 70%
Recommended flow velocity	-12...+12 m/s / -40...+40 ft/s

### Installation conditions

Installation	Take care that flow sensor is always fully filled.
	For information refer to <i>Installation</i> on page 14.
Flow direction	Forward and reverse
	Arrow on flow sensor indicates positive flow direction.
Inlet run	≥ 5 DN (without disturbing flow, after a single 90° bend)
	≥ 10 DN (after a double bend 2x 90°)
	≥ 10 DN (behind a control valve)
Outlet run	≥ 2 DN
Dimensions and weights	For information refer to <i>Dimensions and weights</i> on page 11.

### Materials

Sensor housing	DN10...40: GTW-S 38
	DN50...150: sheet steel
Measuring tube	Austenitic stainless steel
Liner	PFA
Connection box (only remote versions)	Die-cast aluminium (polyurethane coated)
	Option: stainless steel
Measuring electrodes	Hastelloy® C
Grounding rings	DN10...15: integrated stainless steel 316 (1.4571) (AISI 316 Ti)
	DN25...150: separate stainless steel 316 (1.4571) (AISI 316 Ti)
	Grounding rings can be omitted with virtual reference (option for the IFC 300 converter).
Stud bolts and nuts	DN40...150: rubber centering sleeves
	Option: steel, stainless steel

### Process connections

EN 1092-1	DN10...150 in PN 16...40
ASME	3/8...6" in 150...300 lb
JIS	DN10...150 in JIS 10...20 K

**Electrical connections**

Signal cable	Only for remote systems
Type A	Standard cable, double shielded. Max. length: 600 m / 1950 ft (dep. on electrical conductivity and measuring sensor). See documentation of the converter for more information.
Type B	Optional cable, triple shielded. Max. length: 600 m / 1950 ft (dep. on electrical conductivity and measuring sensor). See documentation of the converter for more information.

**Approvals and certifications**

<b>CE</b>	
	This device fulfills the statutory requirements of the EC directives. The manufacturer certifies successful testing of the product by applying the CE mark.
Electromagnetic compatibility	Directive: 2004/108/EC and A1, A2 NAMUR NE21/04
	Harmonized standard: EN 61326-1 : 2006
Low Voltage Directive	Directive: 2006/95/EC
	Harmonized standard: EN 61010 : 2001
Pressure Equipment Directive	Directive: 97/23/EC
	Category I, II or SEP
	Fluid group 1
	Production module H
<b>Other approvals and standards</b>	
Protection category acc. to IEC 529 / EN 60529	Standard: IP 66/67 (NEMA 4/4X/6)
	Optional: IP 68 (NEMA 6P)
Vibration test	IEC 68-2-6

## 2.2 Dimensions and weights

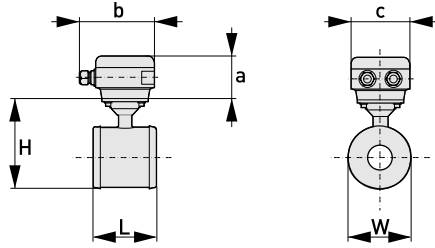
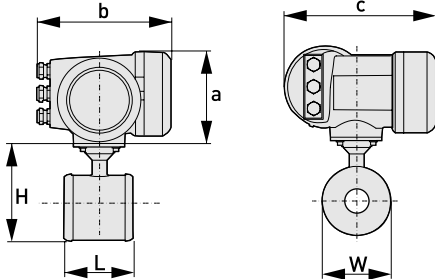
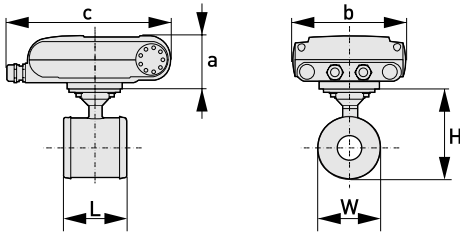
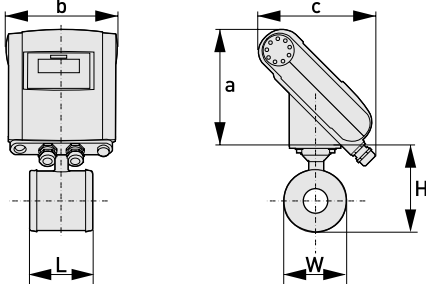
Remote version		<p>a = 77 mm / 3.1"</p> <p>b = 139 mm / 5.5" ①</p> <p>c = 106 mm / 4.2"</p> <p>Total height = H + a</p>
Compact version with IFC 300		<p>a = 155 mm / 6.1"</p> <p>b = 230 mm / 9.1" ①</p> <p>c = 260 mm / 10.2"</p> <p>Total height = H + a</p>
Compact version with IFC 100 (0°)		<p>a = 82 mm / 3.2"</p> <p>b = 161 mm / 6.3"</p> <p>c = 257 mm / 10.1" ①</p> <p>Total height = H + a</p>
Compact version with IFC 100 (45°)		<p>a = 186 mm / 7.3"</p> <p>b = 161 mm / 6.3"</p> <p>c = 184 mm / 7.3" ①</p> <p>Total height = H + a</p>

① The value may vary depending on the used cable glands.

- All data given in the following tables are based on standard versions of the sensor only.
- Especially for smaller nominal sizes of the sensor, the converter can be bigger than the sensor.
- Note that for other pressure ratings than mentioned, the dimensions may be different.
- For full information on converter dimensions see relevant documentation.

Nominal size		Dimensions [mm]			Approx. weight [kg]
DN	PN [bar]	L	H	W	
10	40	68	137	47	1.7
15	40	68	137	47	1.7
25	40	54	147	66	1.7
40	40	78	162	82	2.6
50	40	100	151	101	4.2
80	40	150	180	130	5.7
100	16	200	207	156	10.5
150	16	200	271	219	15.0

Nominal size		Dimensions [inches]			Approx. weight [lb]
ASME	PN [psi]	L	H	W	
3/8"	580	2.68	5.39	1.85	3.7
1/2"	580	2.68	5.39	1.85	3.7
1"	580	2.13	5.79	2.6	3.7
1 1/2"	580	3.07	6.38	3.23	5.7
2"	580	3.94	5.94	3.98	9.3
3"	580	5.91	7.08	5.12	12.6
4"	232	7.87	8.15	6.14	23.1
6"	232	7.87	10.67	8.62	33.1

- Pressures are applicable at 20°C / 68°F.
- For higher temperatures, the pressure ratings are as per ASME B16.5 (up to 24").

## 2.3 Measuring accuracy

### Reference conditions

- Medium: water
- Temperature: 20°C / 68°F
- Pressure: 1 bar / 14.5 psi

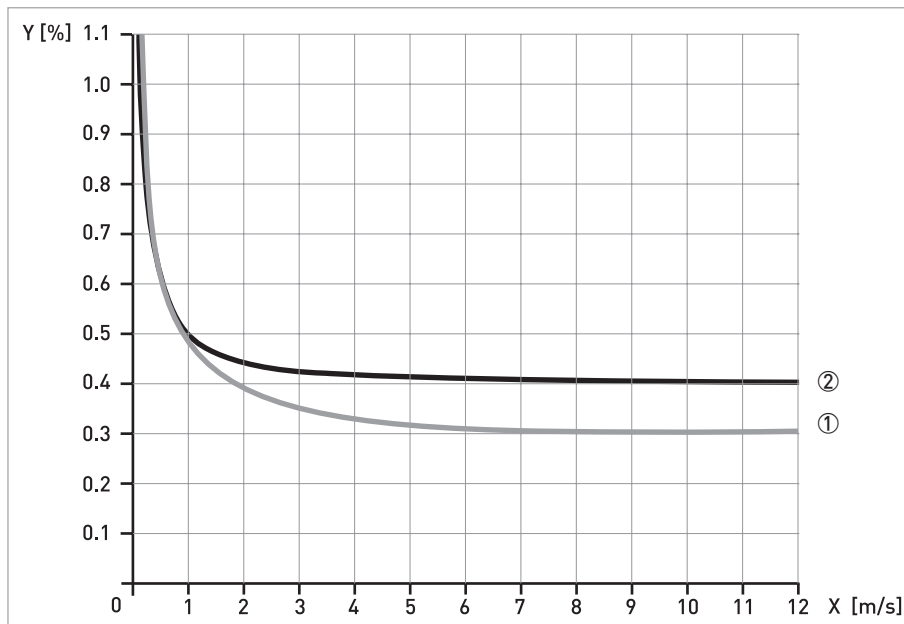

X [m/s]: flow velocity

Y [%]: deviation from the actual measured value (mv)

Compact with IFC 300	Accuracy	Curve
DN10...150 / 3/8...6"	0.3% of mv + 2 mm/s	①

Compact with IFC 100	Accuracy	Curve
DN10...150 / 3/8...6"	0.4% of mv + 1 mm/s	②

### 3.1 Notes on installation

*Inspect the cartons carefully for damage or signs of rough handling. Report damage to the carrier and to the local office of the manufacturer.*

*Check the packing list to check if you received completely all that you ordered.*

*Look at the device nameplate to ensure that the device is delivered according to your order. Check for the correct supply voltage printed on the nameplate.*

### 3.2 Intended use

The **OPTIFLUX 1000** flowmeter measures the volumetric flow rate of electrically conductive liquids, acids, alkaline solutions, pastes and slurries, also with very high solid contents.

### 3.3 Installation conditions

#### 3.3.1 Inlet and outlet

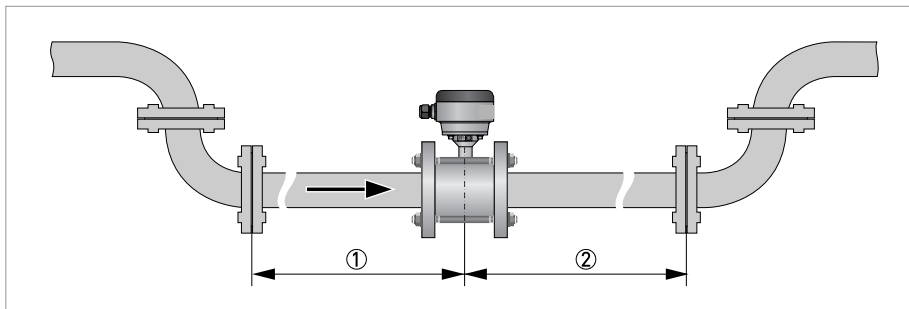

Figure 3-1: Recommended inlet and outlet

- ①  $\geq 5$  DN
- ②  $\geq 2$  DN

#### 3.3.2 Mounting position

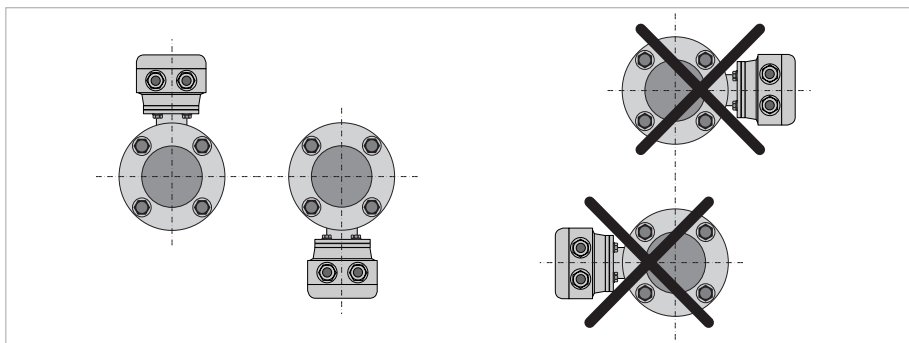

Figure 3-2: Mounting position

### 3.3.3 Flange deviation

Max. permissible deviation of pipe flange faces:  
 $L_{max} - L_{min} \leq 0.5 \text{ mm} / 0.02''$

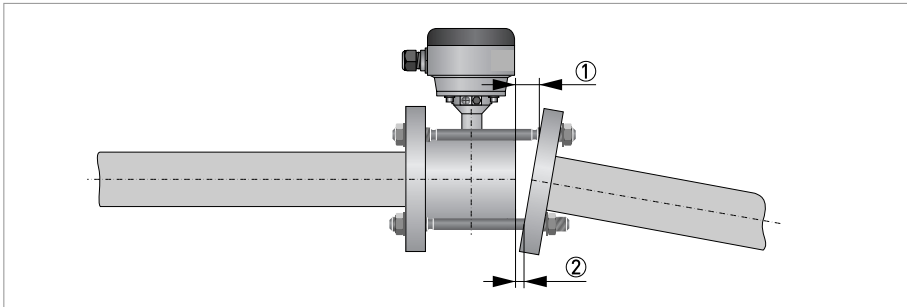

Figure 3-3: Flange deviation

- ①  $L_{max}$
- ②  $L_{min}$

### 3.3.4 T-section

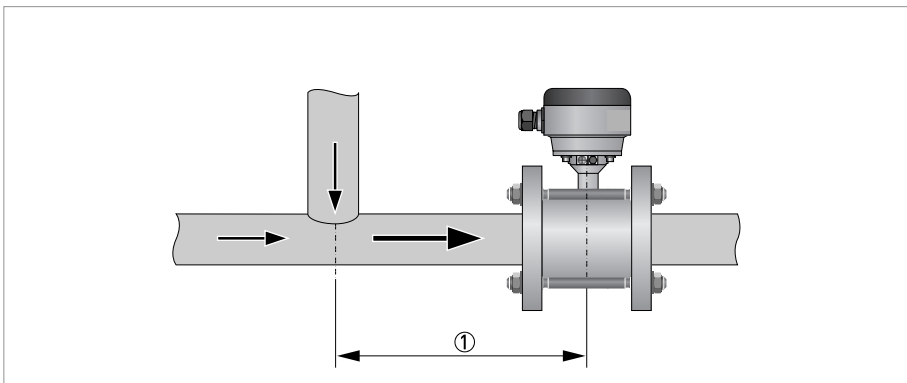

Figure 3-4: Distance after T-sections

- ①  $\geq 10 \text{ DN}$

### 3.3.5 Vibration

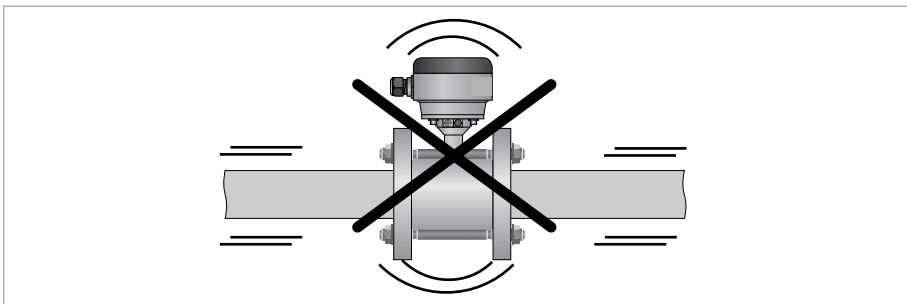

Figure 3-5: Avoid vibrations

3.3.6 Magnetic field

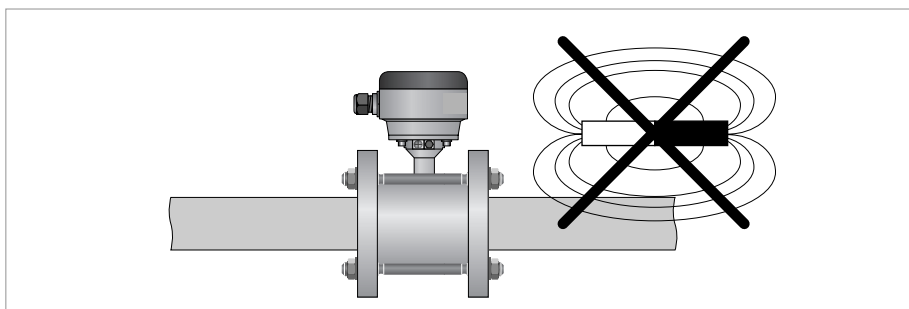

Figure 3-6: Avoid magnetic fields

3.3.7 Bends

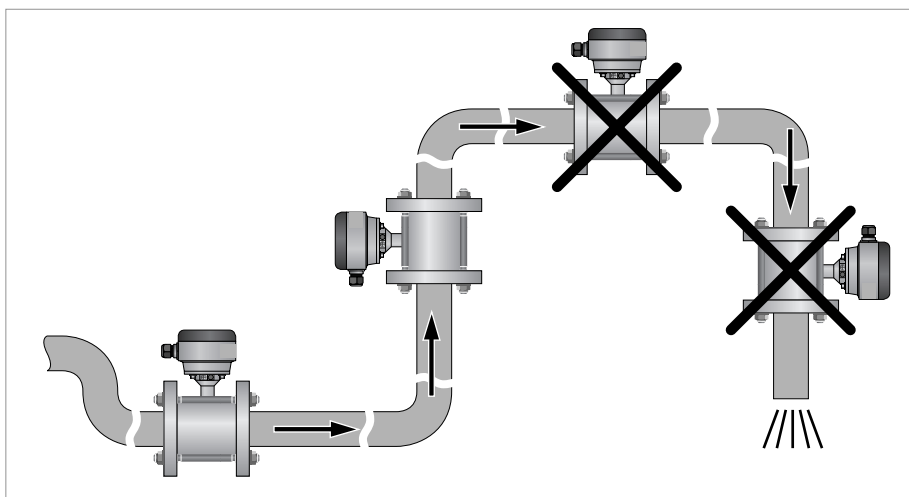

Figure 3-7: Installation in bending pipes

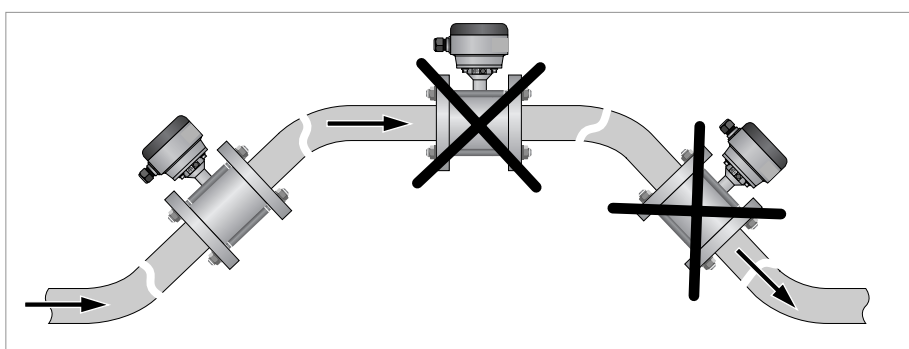

Figure 3-8: Installation in bending pipes



### 3.3.8 Open discharge

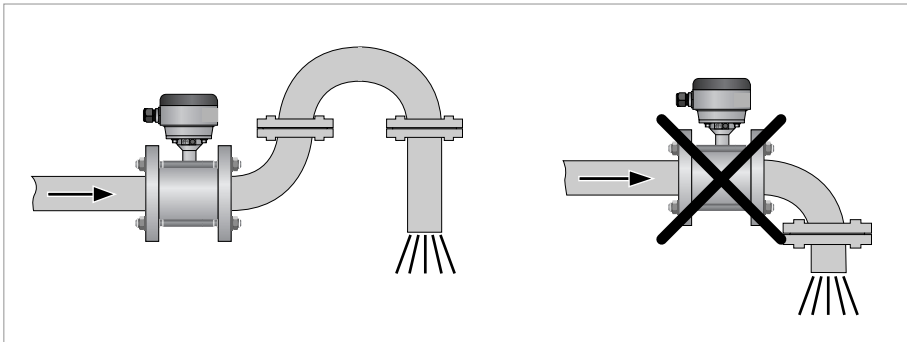

Figure 3-9: Installation before an open discharge

### 3.3.9 Control valve

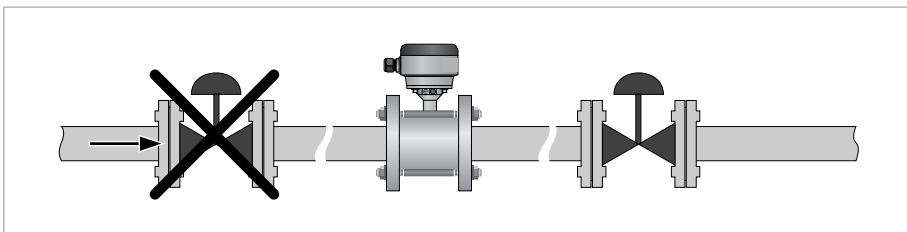

Figure 3-10: Installation before control valve

### 3.3.10 Air venting

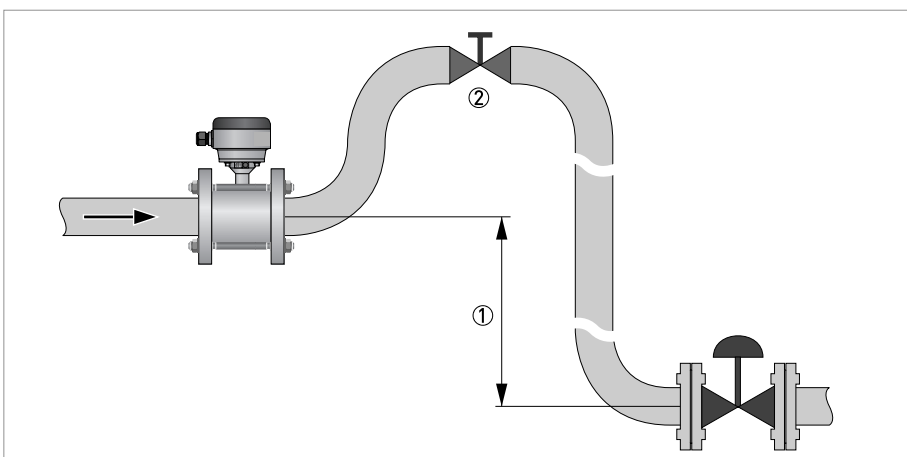

Figure 3-11: Air venting

①  $\geq 5$  m

② Air ventilation point

### 3.3.11 Pump

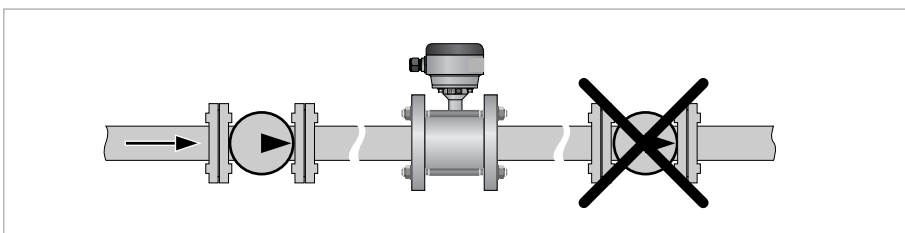

Figure 3-12: Installation after pump

### 3.3.12 Temperatures

*Protect the device from direct sunlight.*

Temperature range	Process [°C]		Ambient [°C]		Process [°F]		Ambient [°F]	
	min.	max.	min.	max.	min.	max.	min.	max.
Separate flow sensor	-25	120	-25	65	-13	248	-13	149
Compact + IFC 300 C	-25	120	-25	65	-13	248	-13	149
Compact + IFC 100 C	-25	120	-25	65	-13	248	-13	149

## 4.1 Safety instructions

*All work on the electrical connections may only be carried out with the power disconnected. Take note of the voltage data on the nameplate!*

*Observe the national regulations for electrical installations!*

*For devices used in hazardous areas, additional safety notes apply; please refer to the Ex documentation.*

*Observe without fail the local occupational health and safety regulations. Any work done on the electrical components of the measuring device may only be carried out by properly trained specialists.*

*Look at the device nameplate to ensure that the device is delivered according to your order. Check for the correct supply voltage printed on the nameplate.*

## 4.2 Grounding

*The device must be grounded in accordance with regulations in order to protect personnel against electric shocks.*

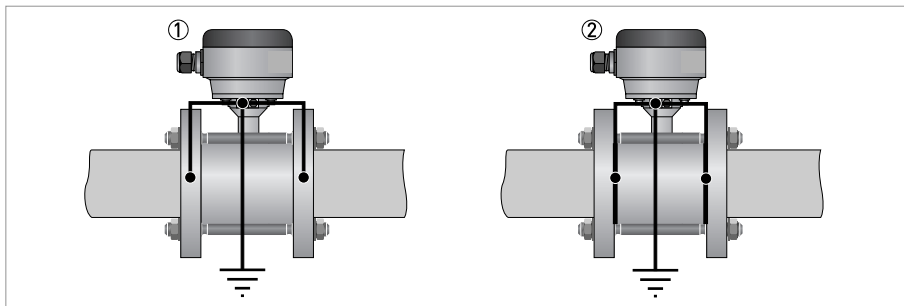

Figure 4-1: Grounding

- ① Metal pipelines, not internally coated. Grounding without grounding rings!
- ② Metal pipelines with internal coating and non-conductive pipelines. Grounding with grounding rings!

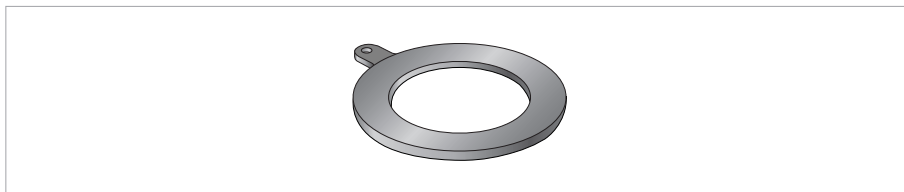

Figure 4-2: Grounding ring number 1

### Grounding ring number 1 (Optional for DN25...100):

- 3 mm / 0.1" thick (tantalum: 0.5 mm / 0.1")

### 4.3 Virtual reference for IFC 300 (C, W and F version)

The virtual reference option on the IFC 300 flow converter provides complete isolation of the measurement circuit.

The benefits of virtual reference are that grounding rings or grounding electrodes can be omitted, safety increases by reducing the number of potential leakage points and the installation of the flowmeters is much easier.

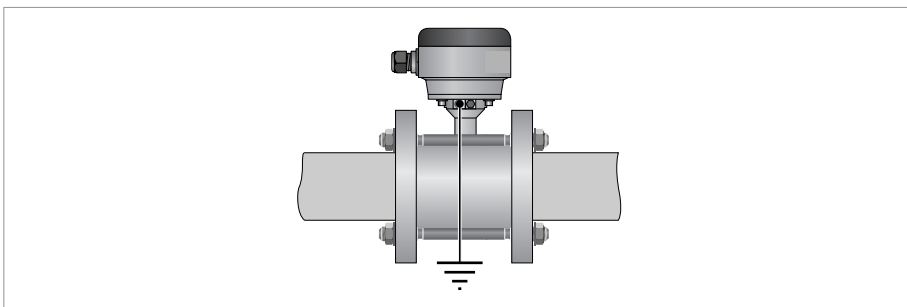

Figure 4-3: Virtual reference

**Possible if:**

- $\geq$  DN10
- Electrical conductivity  $\geq 200 \mu\text{S}/\text{cm}$
- Electrode cable max. 50 m / 164 ft, type DS







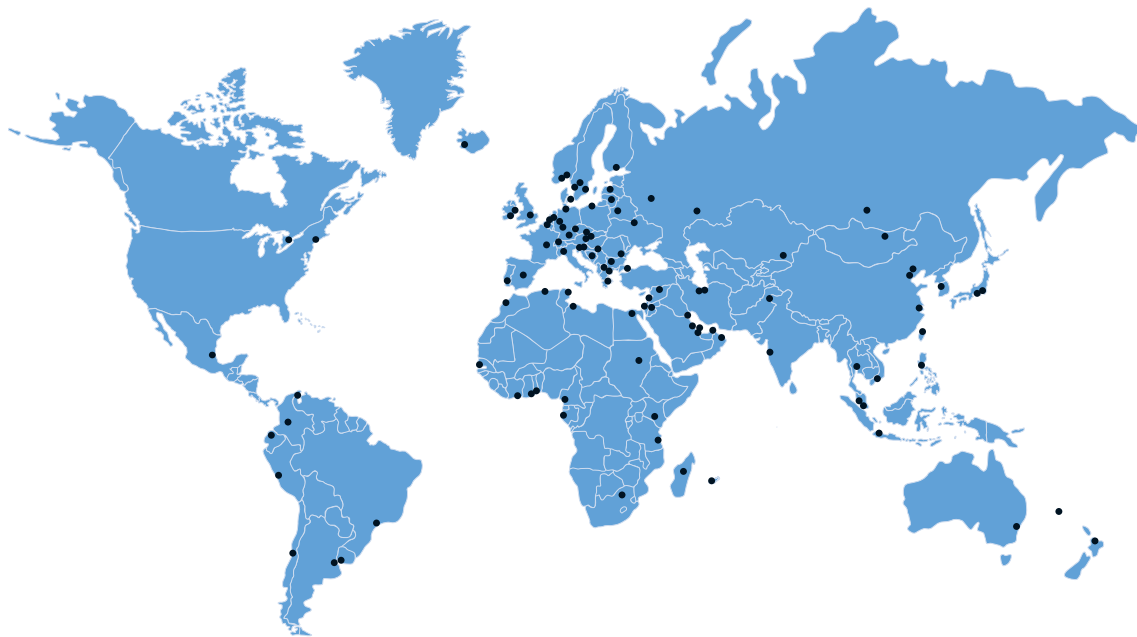

## KROHNE product overview

- Electromagnetic flowmeters
- Variable area flowmeters
- Ultrasonic flowmeters
- Mass flowmeters
- Vortex flowmeters
- Flow controllers
- Level meters
- Temperature meters
- Pressure meters
- Analysis products
- Measuring systems for the oil and gas industry
- Measuring systems for sea-going tankers

Head Office KROHNE Messtechnik GmbH  
Ludwig-Krohne-Str. 5  
D-47058 Duisburg (Germany)  
Tel.: +49 (0)203 301 0  
Fax: +49 (0)203 301 10389  
info@krohne.de

The current list of all KROHNE contacts and addresses can be found at:  
[www.krohne.com](http://www.krohne.com)

**KROHNE**